

---

# PATENT SPECIFICATION

145,651

Application Date: 12th December, 1949.

No. 31,569/49.

Complete Specification Published ..... 9th November, 1950.

Complete Specification Accepted ..... 7th March, 1952.

Class 32.6

Drawing attached.

---

## COMPLETE SPECIFICATION.

### "Automatic control for cocky-chaff savers."

I, VINCENT DENIS CAHILL, of Nangeenan, in the State of Western Australia, Commonwealth of Australia, Farmer, hereby declare this invention, and the manner in which it is to be performed, to be fully described and ascertained in and by the following Statement:—

THIS INVENTION relates to an automatic control for cocky-chaff savers.

The saving of the so-called "cocky-chaff" is an important economy measure in harvesting wheat crops, particularly in dry areas. These cocky-chaff savers are associated with the harvesters and have a door or other dumping arrangement so that the accumulated material can be discharged when required.

At present, these controls are manually operated. This in practice results in uneven

discharge and frequently in the chaff saver becoming choked through failure to dump the contents soon enough.

The present invention relates to automatic means for dumping the cocky-chaff, although these means do not prevent manual operation if it is desired to discharge the contents before the automatic means come into operation.

The invention will readily be understood by reference to the accompanying drawings showing a preferred form thereof. In these drawings:—

Figure 1 is a side elevation showing the arrangement in association with the crop wheel of a harvester, whilst:—

Fig. 2 is a plan thereof.

As shown in these drawings, the crop wheel is referenced 10 and the main axle 11. Mounted on this main axle is a supporting bracket 12, whilst also mounted thereon is a longitudinal supporting bracket 13. There is a vertical bracket 14 also mounted on the shaft, and this at its upper end carries the end of a shaft 15 on which a collar 16 is adapted to rotate. Connected to this collar is a sprocket 17 having comparatively large teeth, and this sprocket is adapted to be advanced a distance of one tooth at each revolution of the crop wheel by means of a knocker 18 which is attached to the wheel.

A spring 19 surrounds the shaft 15 on one side, and this spring is caused to press up against the collar by a pressure collar 20 connected to the shaft by a set screw. The purpose of this arrangement is to prevent the collar over-running.

Formed on the collar 16 is a worm 21 of comparatively large size, and adapted to engage in the said worm is a control lever 22, one end of which is engaged by a spring 23 that tends to pull the control lever up against one side of the worm and also operates the control lever, as will subsequently become apparent.

Connected to the control lever near one end by passing through a square or the like formed in such lever is a control shaft 24 which at the end passing through the control lever 22 is also of square form so as to be movable by the said lever when it is operated.

The control shaft passes through a bearing bracket 25 connected to the frame of the harvester, and it has connected thereto an upstanding extension lever 26 which is connected to a control wire 27 that leads to the dumping arrangement that discharges the cocky-chaff. There is a guide member 28 that is supported by and connected to a bracket 29 that is fixed to the longitudinal bracket 13 supported from the main shaft. A strut 30 also connects the guide and bracket member. The guide member is supported as illustrated so that at one end it is close to the rim of the crop wheel, and then extends upwardly and laterally away from the wheel.

The end of the guide member is formed with a notch 31. On the crop wheel there is a laterally extending hook member 32, and there is an additional knocker member 33, the purpose of which will subsequently become apparent. A release lever 34 is supported close to the commencement of the worm 21, and such release lever extends in the form of a shaft 35 which can be controlled by the person driving the harvester through any appropriate lever mechanism (which is not shown).

The arrangement described operates in the following manner.

When the crop wheel rotates, each time it moves around once it turns the sprocket 17 through a distance equal to that between two teeth. This turns the worm 21 and so progressively moves the control lever 22 laterally. This continues until the lever comes to the end of the worm, when under the influence of its spring 23 it moves laterally against the side of the crop wheel 10 and is then picked up and engaged by the hook member 32 and carried around. This turns the control lever 22 and of course the control shaft 24 and the extension lever 26, and so operates the control wire 27, which in turn operates the dumping mechanism for discharging the cocky-chaff.

When the position is reached where the hook member 32 has come to the end of the control lever 22, this synchronises with the position when the lever is in line with the end of the guide member 28. The said lever is thereupon released and jumps into the notch 31 at the end of the guide member. Shortly afterwards, the knocker 33 engages against the control lever 22 and knocks it out of the notch 31, whereupon it moves down on the back side of the guide member 28 and so takes up a position at or about the commencement of the worm 21. Then of course the operation described is repeated.

It will therefore be apparent that the effect of the mechanism is to cause dumping of the cocky-chaff at regular intervals, solely dictated by the distance travelled by the crop wheel 10.

In some cases it may be desired to dump the cocky-chaff before the full period has expired. In such a case the release lever

34 can be moved so that it engages against the control lever 22 and then the release lever is moved further so as to push the control lever out of the worm 21, whereupon under spring action it jumps into position against the crop wheel and is almost immediately engaged by the hook member 32 and operated to cause dumping of the cocky-chaff.

It will therefore be further apparent that not only does this apparatus provide for the automatic dumping of the cocky-chaff, but that by means of the manual release referred to, the cocky-chaff can be dumped at more frequent intervals by means of manual operation, and that such manual operation merely involves the slight effort of moving the control lever out of engagement with the worm 21.

Having now fully described and ascertained my said invention, and the manner in which it is to be performed, I declare that what I claim is:—

(1) Automatic control for cocky-chaff savers that includes a worm that is slowly rotated under the influence of the harvester crop wheel; a control lever registering with and moved laterally by the worm; a spring connected to the control lever so as to move it laterally to the crop wheel when it has travelled to the end of the worm; a hook member on the wheel that engages the control lever and pulls it around, thereby causing such lever through a wire or similar control to cause discharge of the cocky-chaff.

(2) Automatic control for cocky-chaff savers as set out in Claim 1, in which there is a guide member supported so that one end is close to the crop wheel and so positioned that when the control lever is released from the hook on the wheel, it temporarily comes to rest against the end of the guide whilst a knocker on the wheel subsequently displaces the control lever, whereupon under spring action it moves so as to take up a position at the beginning of the worm, after which its lateral progress continues under the action thereof.

(3) Automatic control for cocky-chaff savers as set out in Claim 1 or 2, in which

the worm is carried by a collar connected to a sprocket that is progressed in rotation one tooth each time a knocker on the crop wheel engages it.

(4) Automatic control for cocky-chaff savers as set out in Claim 1, 2 or 3, in which the control lever can be moved out of engagement with the worm by means of a manually operated releasing lever, so enabling the cocky-chaff to be dumped at any time, irrespective of the automatic arrangement.

(5) Automatic control for cocky-chaff savers comprising the combination of a crop wheel; a main axle; a vertical bracket supported from the main axle; a shaft supported by the vertical bracket; a collar running on the shaft; a sprocket connected to the collar; a knocker on the crop wheel to move the sprocket at each revolution; a worm formed on the collar; a control lever adapted to be moved by the worm; a spring engaging the end of the control lever; a control shaft connected to the control lever; an extension lever on the control shaft; and an operating wire connected to the extension lever and passing back to the dumping mechanism for the cocky-chaff.

(6) Automatic control for cocky-chaff savers as set out in Claim 5, further characterised by the provision of a guide member supported by a bracket so as to be close to the crop wheel at one end; a hook member attached to the crop wheel so as to engage the control lever when it has been released from the worm; and another knocker attached to the crop wheel so as to release the control lever from the end of the guide after it has been released thereto by the hook.

(7) Automatic control for cocky-chaff savers as set out in Claim 6, together with a release lever that is adapted to engage the control lever at will; and an extension of such control lever in the form of a shaft controlled by the operator.

(8) Automatic control for cocky-chaff savers as set out in Claims 1 to 7, including the use of a spring and a pressure collar so as to hold the spring against the collar

carrying the worm and so prevent over-running.

(9) Automatic control for cocky-chaff savers substantially as herein described and as illustrated in the accompanying drawings.

Dated this twenty-eighth day of July, 1950.

7

VINCENT DENIS CAHILL,

By his Patent Attorney,

P. M. BONNERUP,

Fellow Institute of Patent Attorneys  
of Australia.

Witness: Mavis Wahl.

8

**Fig. 1,**

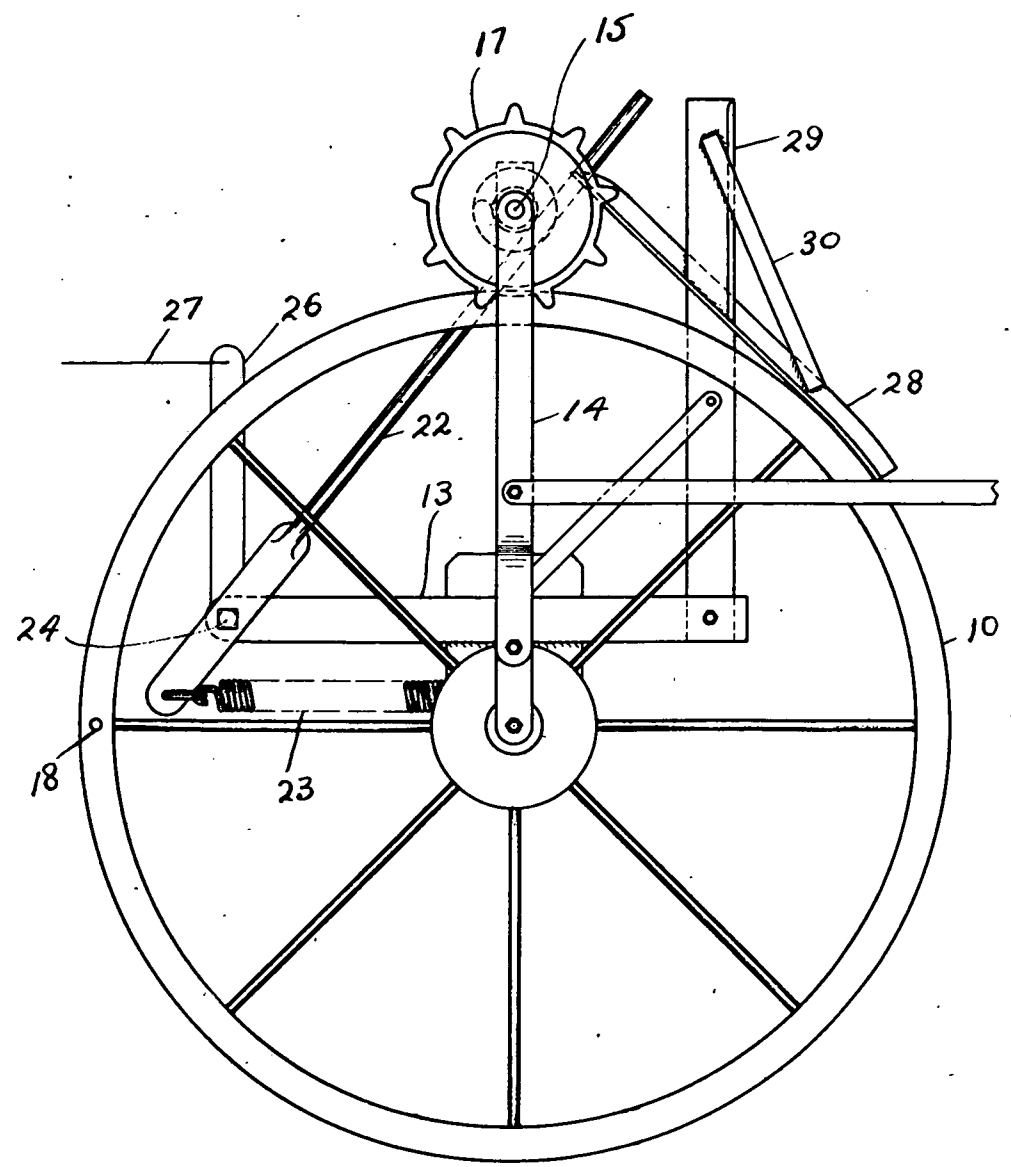

**Fig. 2,**

